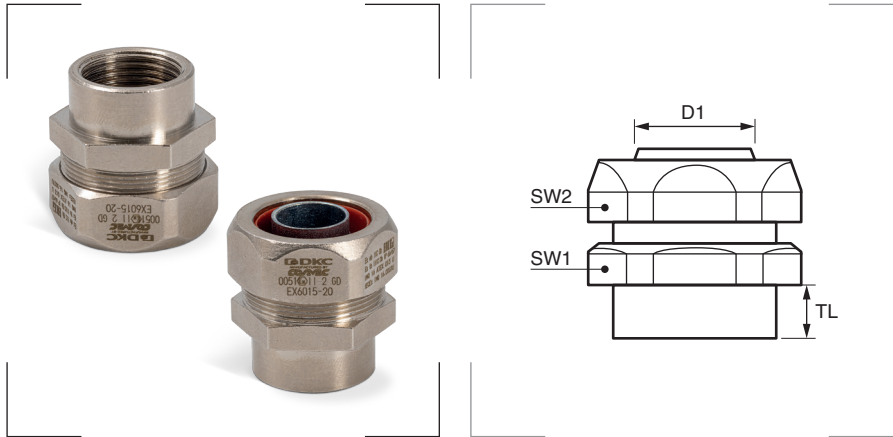

Racor hembra para tubos LIQUID-TIGHT-RFZ

Marcado del equipo

Ex II 2 GD Ex e IIC Gb/Ex tb IIIC Db

Grado de protección

Polvo/agua: IP66 - IP67.

Materiales

 Cuerpo y tuerca de latón niquelado.
 Abrazadera de aleación de zamak.
 Junta del tubo: casquillo cónico de silicona.

Certificados y normas aplicables

Temperatura de trabajo

-45°C hasta +85°C.

Recomendado para los siguientes tubos

 Tubo metálico LIQUID-TIGHT-RFZ  pág. 31

 Tubo metálico LIQUID-TIGHT-RFZ-PU  pág. 32

Referencia	Modelo DN Ø mm	Métrica EN 60423	D1 mm	SW1 mm	SW2 mm	TL mm	Embalaje unidades
EX6015-10A	10	M 16 x 1,5	8,5	22	24	12,0	1
EX6015-12A	12		10,0	24	26	12,0	1
EX6015-16A	16		13,8	28	30	14,5	1
EX6015-20	16	M 20 x 1,5	13,8	28	30	14,5	1
EX6015-2020	21		18,0	35	37	14,0	1
EX6015-25	21	M 25 x 1,5	18,0	35	37	12,0	1
EX6015-2527	27		23,0	42	45	14,0	1
EX6015-32A	27	M 32 x 1,5	24,0	42	45	15,0	1
EX6015-3235	35		30,0	50	52	15,0	1
EX6015-4035	35	M 40 x 1,5	32,0	50	52	17,0	1
EX6015-40	40		38,0	58	61	20,0	1
EX6015-5040	40	M 50 x 1,5	38,0	58	61	23,0	1
EX6015-50	51		48,0	70	74	19,5	1
EX6015-6350	51	M 63 x 1,5	48,0	70	74	21,5	1